

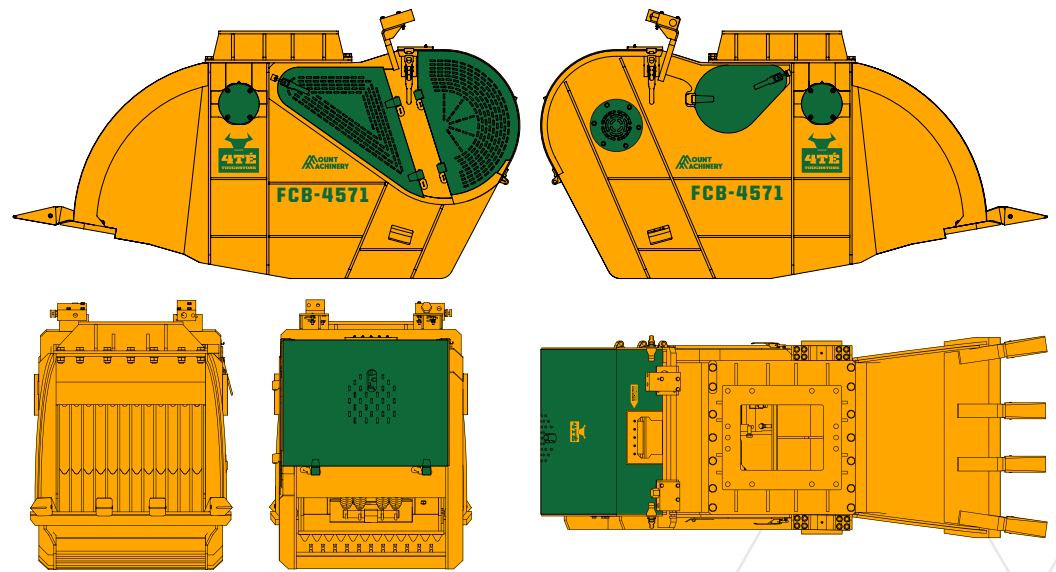

MOUNT MACHINERY

Crusher Bucket



The 4TÉ TouchStone Crusher Bucket; a WOW in the world of crusher buckets! On small crushing jobs is where you'll find the crusher bucket, anything up to 1000 ton. But don't stop there; in some operations it fits better than a conventional crusher altogether. Years of development have gone into the design. It's no mere attachment; it's proper, it's proven, and it's a high performer!

Mount Machinery
137 Gelderd Road,
Leeds
LS12 6BZ

Telephone
+44 (0) 113 244 0244

sales@mountmachinery.com
www.mountmachinery.com





Crusher Bucket

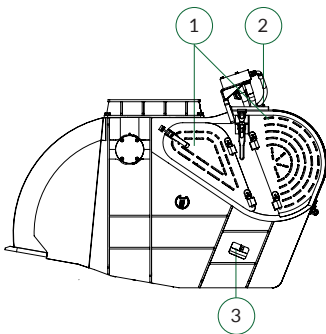

Key

- 1. Easy access to inner workings
- 2. Central greasing point
- 3. Output size adjuster

Performance features:

- Crush up to 300 ton per day depending on material
- Variable crushing output size from 30 to 150mm. Capable of crushing down to type 1 size material.
- Suited to 13 to 60 ton excavators.

Quality Control

- Low stress on your excavator; bucket operates at a low pressure and a low flow

- Well balanced; 2 fly wheels, not one
- In-house development of motor and safety valve; parts sourced globally
- Reliable gear motor

Ease of use

- Ideal for compact sites where access is restricted
- Simple output size adjustment procedure
- External central point for all internal bearings

	FCB-2471	FCB-4571	FCB-6071
Technical Details			
Excavator weight range (T)	13-24	21-45	35-60
Operating weight - excluding saddle (Kg)	1900	3500	4500
Operating pressure (bar)	180 - 200	180 - 200	180 - 200
Required flow (L/min)	110 - 115	150 - 160	150 - 160
Overall height (mm)	1291	1432	1478
Overall width (mm)	886	1080	1424
Overall length (mm)	1903	2713	2775
Output size (mm)	30 - 150	30 - 150	30 - 150
Feeder opening (mm)	600 x 550	800 x 700	900 x 700

Mount Machinery
 137 Gelderd Road,
 Leeds
 LS12 6BZ

Telephone
 +44 (0) 113 244 0244

sales@mountmachinery.com
 www.mountmachinery.com

