

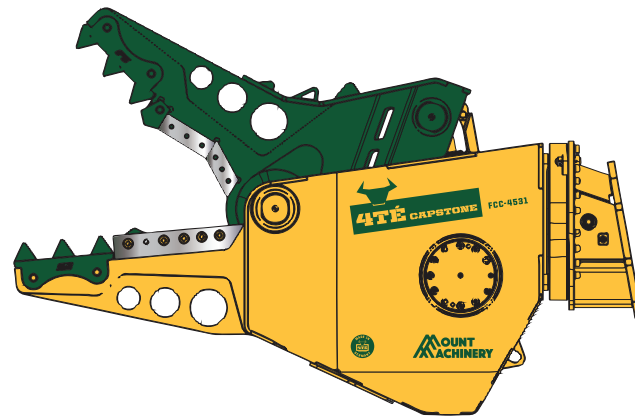

Concrete Cutter



The first phase in demolishing a concrete building is to cut and drop. This simply means to cut out sections as large as safely possible for efficiency and bring to the ground for processing. That is exactly what the 4TÉ CapStone Concrete Cutter is designed for. It has narrow jaws to cut through concrete rather than pulverise it and longer cutting blades for shearing steel at the same time.

Being German made and full of innovative features, this truly is an outstanding demolition attachment!

What does 'Made in Germany' mean to you?

...to us it means;

- superb quality,
- built to perform,
- built to last,
- and the pinnacle of innovation

resulting in this great product we have to offer you.

Designed for Performance!

Such intricate care and attention to detail has been expended that even the geometry of the construction has been carefully calculated so that the crushing force is optimized by creating maximum leverage power at the point where the most force is required. The point where the most force is required for crushing concrete is hugely different to that point when cutting metal. This is why a shear and a pulveriser cannot be incorporated into the same attachment and achieve optimum performance in both. But the

Concrete Cutter has shear blades to accommodate mixed building structures with reasonable amounts of steel and concrete so you don't have to change attachments.

- tremendously high crushing force!
- optimized crushing force by the geometry of the construction
- increased power to weight ratio, more power / reduced weight

Extremely Fast Cycle Time

The open and close speed is crucial in demolition. One second in cycle time can have a big impact on how long it takes to demolish a building. So we've eliminated the flow restrictions right from the excavator to the ram producing a stunningly fast cycle time. Check out the features below:

- extremely large ports through rotary coupling with significantly less resistance to achieve higher flow
- special bespoke speed valve installed
- large internal bore hydraulic piping through to ram



Mount Machinery
137 Gelderd Road,
Leeds
LS12 6BZ

Telephone
+44 (0) 113 244 0244

sales@mountmachinery.com
www.mountmachinery.com





Concrete Cutter

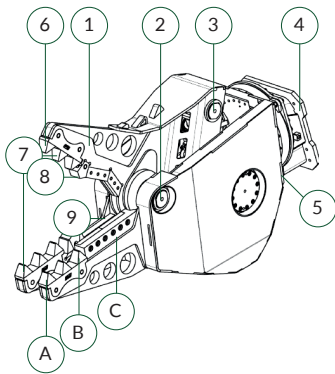

Key

1. Higher forces achieved due to even distribution of forces in moving jaw
2. Widened bearing
3. Cylinder with speed valve and one piece ram and rod eye
4. Bevelled saddle mounting for Kinematics
5. Heavy duty slew ring - double ball bearing array
6. Replaceable wear parts with high durability due to special material and hardening
7. Rotatable and replaceable high tensile crusher teeth - new tooth form concept
8. Cutter and pilot tooth
9. Cutting blade can be turned

A, B, C - See table for information

Easy & Low Cost Maintenance

Maintenance plays a crucial part in demolition efficiency - all our 4TÉ CapStone series attachments are designed with ease of maintenance in mind, reducing downtime and ensuring the product works harder for you.

- replaceable wear parts such as crusher teeth and cutting blades can also be rotated to gain maximum use
- additional side protection on crusher teeth increases wear life expectancy
- no ram bleeding required
- modular design - wear parts interchangeable across several models
- optional link up to central lubrication system on excavator for cylinder and main pin pivot
- on-site replacement of wear parts possible

Easy Handling

Included in the design of this attachment are many little details, each contributing big benefits to

the easy handling of this attachment. The saddle mounting has been placed at an angle for versatility whilst working at height or on the floor

- low net weight
- bevelled saddle mounting for kinematics

Long Lasting Product

Our products are not just designed to perform brilliantly, but are also built to last.

- wear parts made of highly wear resistant casting
- new robust protection for the ram
- harder rod chrome
- better designed locking mechanism for wear parts
- ram rod and eye are one piece for lasting strength
- new form locking innovative construction
- innovative construction ensures low pressure point which means reduced risk of fractures in construction
- extremely high flow accommodation

Technical Details	FCC1431	FCC2231	FCC2831	FCC3531	FCC4531	FCC6531
Excavator Weight Range (T)	5-14	9-22	15-28	20-35	27-45	New model coming soon
Self Weight excluding saddle (kg)	690	1100	1750	2250	2700	
Cycle Time (seconds)	1.9/1.2	1.9/1.2	1.7/1.2	1.9/1.3	2.6/2.0	
Open/Close Flow (l/min)	90	90	200-500	200-500	200-500	
Rotation Flow (l/min)			40-60	40-60	40-60	
Open/Close Max Pressure (bar)	350	350	350	350	350	
Rotation Max Pressure (bar)			140	140	140	
Overall Height (mm)			2120	2650	2850	
Overall Width (mm)			520	720	720	
Jaw Opening (mm)	550	650	750	900	1000	
Jaw Depth (mm)	600	650	650	870	975	
Fixed Jaw Width (mm)			370	434	455	
Moving Jaw Width (mm)			75	90	90	
Shear Blade Length (mm)			400	400	455	
Closing Force at point 'A' (T)	105	120	84	100	125	
Closing Force at point 'B' (T)			120	148	165	
Closing Force at point 'C' (T)			180	294	350	

Mount Machinery
137 Gelderd Road,
Leeds
LS12 6BZ

Telephone
+44 (0) 113 244 0244

sales@mountmachinery.com
www.mountmachinery.com

